







RAS - Installation Instructions Zipshade 100 Inside

Hardware Included		Tools Required					
							
3 mm Allen screw	25 Torque Screw	25 Torque Bit	3/16" Drill Bit	3 mm Allen Wrench	Level	Drill	Two Man Install

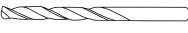
1. Disassemble 3-part Side Channels

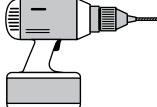
Remove 3 mm Allen screws from front of side channel. Once all screws are removed, take off front cover and remove the inner rail.
DO NOT LOSE SCREWS!

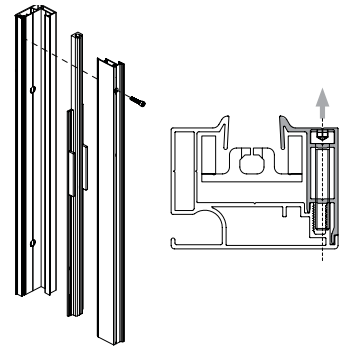

2. Drill Out Holes

Side channels are pre-punched for holes. When drilling out holes use 3/16" drill bit. If shade is outside mount, drill out holes in the back of the channel. If the shade is inside mount, drill out holes on the side of the side channel.

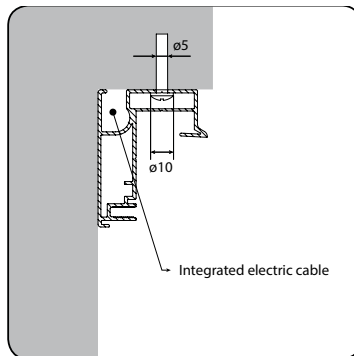

Outside Mount

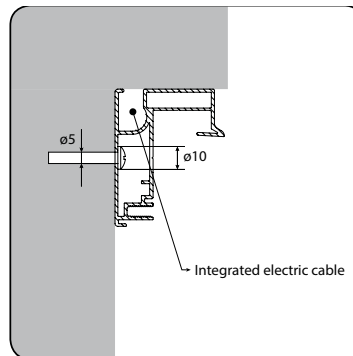

Inside Mount

3. Lifting box into Opening

- From working position, insert both side channel A and Channel B into headbox locking pins. Using both workers, grab each side channel and lift headbox into opening.
- Once headbox and side channels are resting in opening, secure both A and B side channels through top hole.
- Using a level, make sure Side Channel A is plumb. Insert screw in bottom hole. Using a level, make sure Side Channel B is plumb. Prior to securing, double check width at the top and bottom of the side channel. When width is verified and Side Channel B is plumb, insert screw in bottom hole.
Width must be exact for shade to operate properly.
- Continue affixing channels through remaining holes.

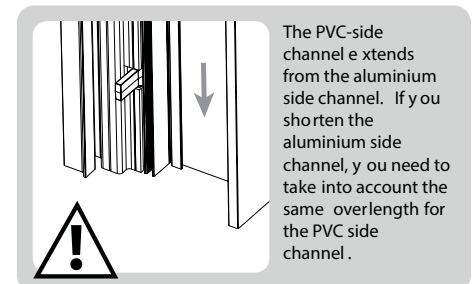
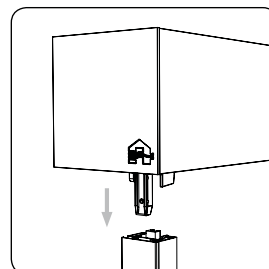

4. Inserting the Zipper into the Inner Rail

- a.) **Inner rails are specific to each side channel.** The top of the inner rail has a “V” shape cut into it. The bottom of the inner rail has a notch. The notch should face the installer when installing - the notch will determine whether the rail belongs in the right or left side channel.
- b.) Slide zipper into the inner rail from bottom to top. To secure the inner rail inside the side channel, hook the foam guides behind the lip in the side channel. At the bottom of the inner rail, hook the notch behind the clip. This will lock the inner rail into position.

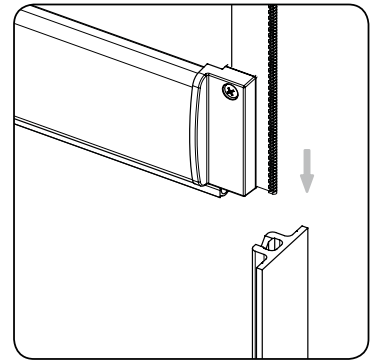









5. Enclosing the Side Channels

Insert the front part of the channel into the installed channel. Insert screws back into side channel to secure.

6. Programming Remotes

Please see corresponding programming instructions.

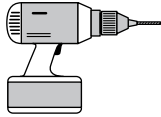
RAS - Installation Instructions Zipshade 100 Outside

Hardware Included		Tools Required					
							
3 mm Allen screw	25 Torque Screw	25 Torque Bit	3/16" Drill Bit	3 mm Allen Wrench	Level	Drill	Two Man Install

1. Disassemble 3-part Side Channels

Remove 3 mm Allen screws from front of side channel. Once all screws are removed, take off front cover and remove the inner rail.
DO NOT LOSE SCREWS!

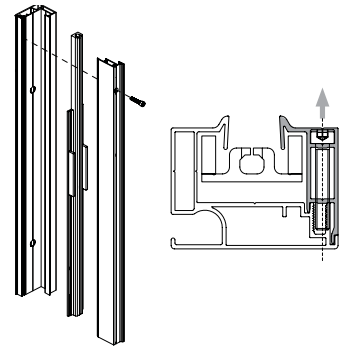

2. Drill Out Holes

Side channels are pre-punched for holes. When drilling out holes use 3/16" drill bit. If shade is outside mount, drill out holes in the back of the channel. If the shade is inside mount, drill out holes on the side of the side channel.

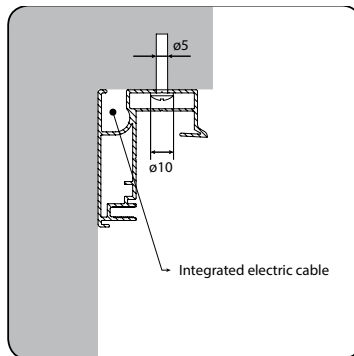

Outside Mount

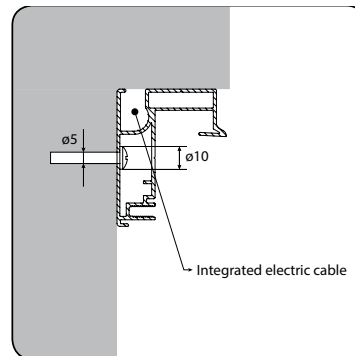

Inside Mount

3. Make your Marks

Using the back piece of one side channel (side channel A), make sure side channel is plumb for installation. Using a pencil, mark the holes.

4. Mounting Side Channel A

Line up holes with your marks. Using a torque 25 screw, drill screw through the top hole of the side channel.

5. Securing the Headbox and Mounting Side Channel B

Using both workers, lift headbox into position. Slide box into the back part of the side channel A ensuring that the locking pins are inserted into the side channel. Place level on headbox, ensuring it is level. Insert Side Channel B into the locking pins on headbox. One headbox is level, screw torque screw into the top hole in Side Channel B. The box should now be locked into both side channels.

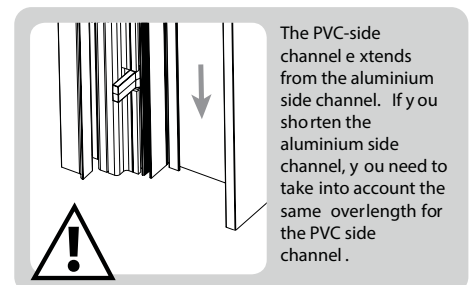
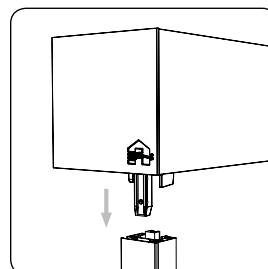

6. Securing the Side Channels

Using a level, make sure Side Channel A is plumb. Insert screw in bottom hole. Using a level, make sure Side Channel B is plumb. Prior to securing, double check width at the top and bottom of the side channel. When width is verified and Side Channel B is level, insert screw in bottom hole. **Width must be exact for shade to operate properly.** Once width is verified at top and bottom, insert remaining screws to secure side channels.

4. Inserting the Zipper into the Inner Rail

- a.) **Inner rails are specific to each side channel.** The top of the inner rail has a “V” shape cut into it. The bottom of the inner rail has a notch. The notch should face the installer when installing - the notch will determine whether the rail belongs in the right or left side channel.
- b.) Slide zipper into the inner rail from bottom to top. To secure the inner rail inside the side channel, hook the foam guides behind the lip in the side channel. At the bottom of the inner rail, hook the notch behind the clip. This will lock the inner rail into position.

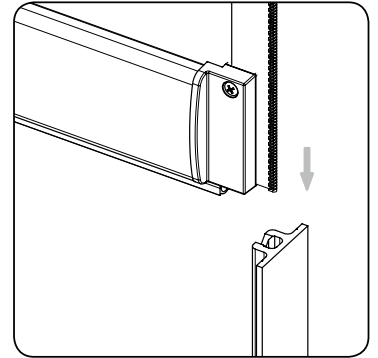

5. Enclosing the Side Channels

Insert the front part of the channel into the installed channel. Insert screws back into side channel to secure.

6. Programming Remotes

Please see corresponding programming instructions.